

ISOMETRIC VIEW  
SCALE 0.500

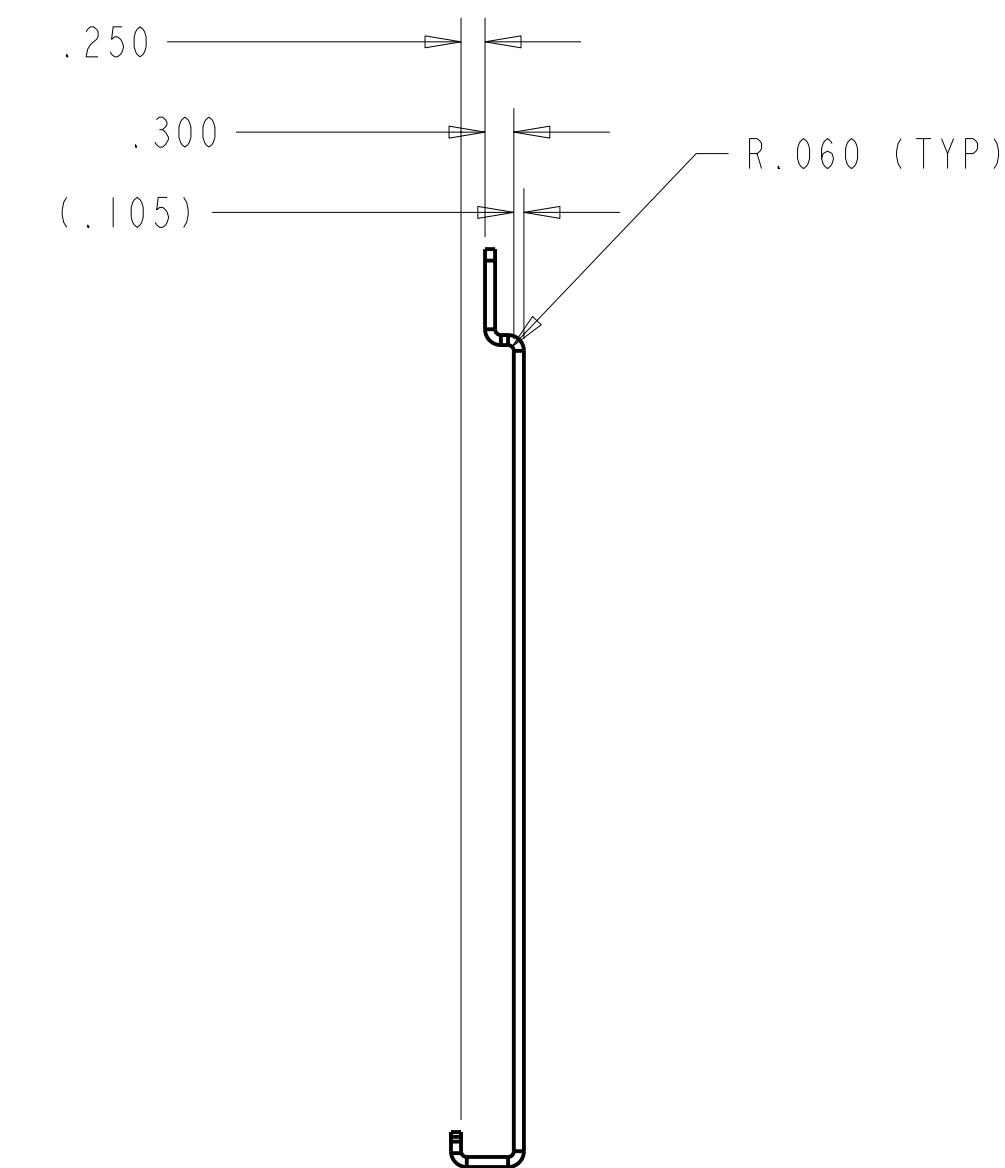
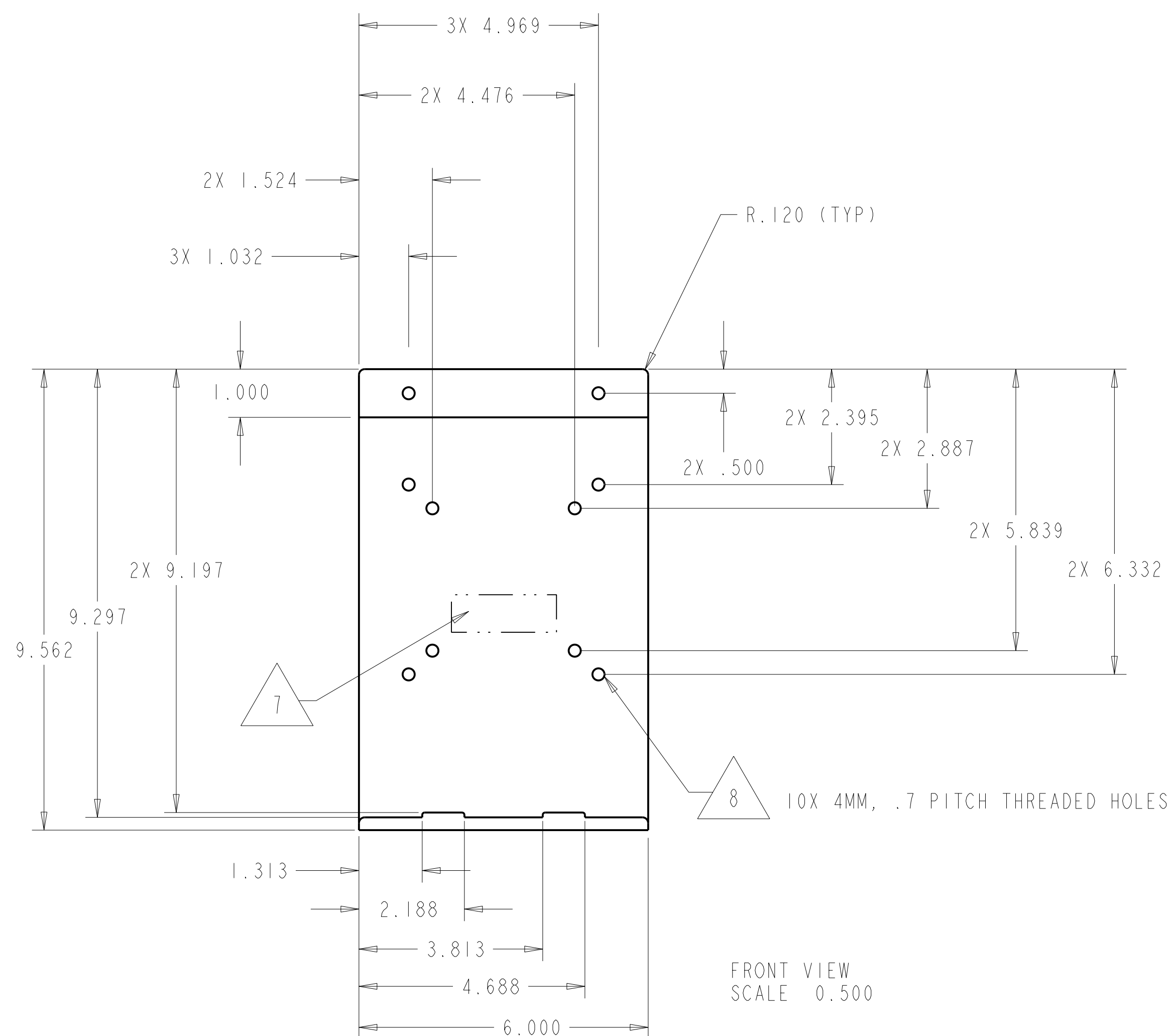

8. NO PAINT ALLOWED IN THREADED HOLES.

7. ADD THE FOLLOWING INFORMATION SHOWN BELOW BY STAMPING AN INDENTING IMPRESSION OR USING PERMANENT INK (CONTRASTING IN COLOR) VISIBLE ONLY FROM THE SIDE INDICATED WITH DIGI INT'L PART NUMBER AND REVISION LEVEL, DATE CODE, AND VENDOR LOGO.

EXAMPLE: DIGI INT'L - 60001099-01 REV. A  
WW-YY  
VENDOR LOGO

6. PAINT ALL EXTERIOR SURFACES UNLESS OTHERWISE SPECIFIED WITH THE FOLLOWING POWDER COAT:  
COLOR: WHITE RAL 9002  
CHEMISTRY: URETHANE  
PARTICLE SIZE: 45-60% THROUGH 325 MESH  
RECOMMENDED FILM THICKNESS: 2.0 - 3.0 MILS  
FINISHED TEXTURE SHALL BE LIGHT  
POWDER COAT CHIP WILL BE SUPPLIED UPON REQUEST

5. CLEAR CHROMATE ELECTROPLATE .0002 THRU .0004 THICK.

4. ALL SURFACES TO BE BURR FREE. REMOVE ALL SHARP EDGES.

3. UNLESS OTHERWISE NOTED BEND RADIUS NOT TO EXCEED .06 MAX.

2. ALL DIMENSIONS TO BE FORMED.

1. DIMENSIONS PER ANSI Y14.5M-1994.

NOTES:

A 103254 NEW RELEASE		TJM	TJM	TJM	3-31-05
REV	ECO	DESCRIPTION OF CHANGE		BY	CKD
APPROVALS		DATE			
DESIGNED	TJM	3-31-05			
DRAWN	TJM	3-31-05			
CHECKED	TJM	3-31-05		TITLE	
ENGINEER	TJM	3-31-05		BRACKET, MEDICAL AMSTERDAM	
MATERIAL		SIZE		CODE	PART NO.
.105 AL 5052-H32		D			60001099-01
FINISH		SCALE		NTS	PRO/ENGINEER
5		DO NOT SCALE DRAWING		SHEET 1 OF 1	

THIS DOCUMENT CONTAINS INFORMATION PROPRIETARY AND CONFIDENTIAL TO DIGI INTERNATIONAL INC. BY ACCEPTING DELIVERY, RECIPIENT AGREES TO RETAIN IT IN CONFIDENCE AND NOT DISCLOSE IT TO OTHERS NOR USE IT FOR ANY PURPOSE OTHER THAN THAT FOR WHICH IT WAS DELIVERED, AND TO PROMPTLY RETURN IT UPON REQUEST.